

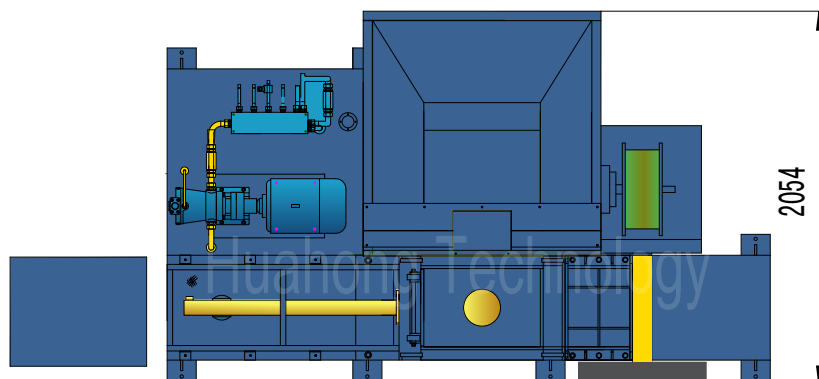

HVA40

Plan View

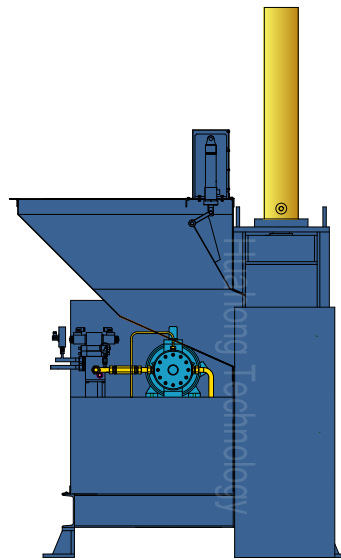

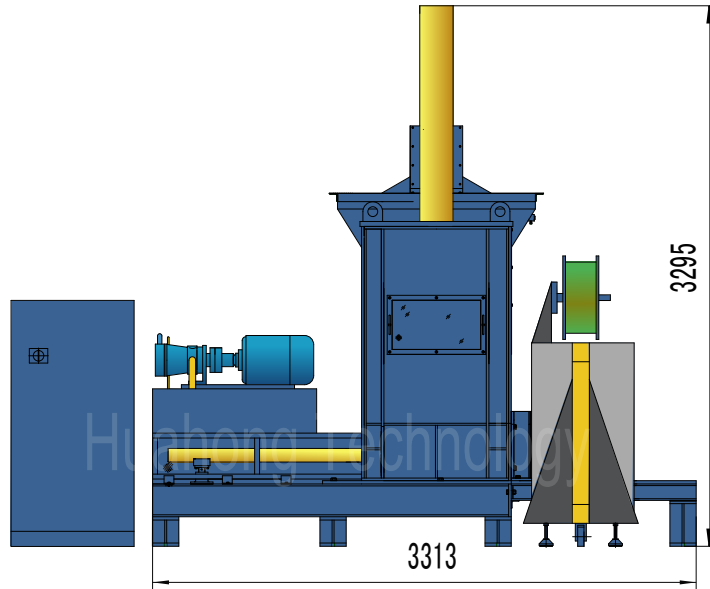

HVA40



Vertical Baler (Automatic Strapping)

Model: HVA40

Power System

Electrical Motor:

Type:	Y160M-4
Rated Power:	11 kW
Rated Speed:	1460 rpm

Hydraulic System

Hydraulic Pump:

Type:	40YCY14-1B
Max Flow Rate:	40 ml/r
Max Operating Pressure:	31.5 MPa

Automatic Strapping System

Strapping Belts:	PP,PET 13.5×(0.5-1.0)mm
Max. Strapping Force:	80 KG
Frame Size:	600×850 mm
Strapping Speed:	25~30 times/min

General Description

Main Cyl. Force:	120 kN
System Pressure:	≤ 20 MPa
Idle Cycle Time:	≤ 230 Sec
Power:	3PH

Control System

PLC Control, Full Automatic..

Hydraulic Oil

Summer:	YB-N46
Winter:	YB-N32

Machine & Bale Size

Main Machine Size (L×W×H):	3350×2100×3400 mm
Press Box Size (L×W×H):	640×430×1350 mm
Bale Size (W×H):	640×430×350 mm
Bale Weight:	15-20 kg (PET Bottle)

Above information are indicative not engaging. Rights reserved to change the data when necessary.